

E50



E50

SYSTEMS FOR WINDOWS AND DOORS

Energy efficiency

Uw (W/m²K): 4,4

Acoustic insulation

Max. acoustic insulation: HRN EN ISO 717-1:1998 - 35dB

Categories achieved at test centre

Air permeability: HRN EN 12207:2001 - 4

Water tightness: HRN EN 12208:2001 - 2A

Wind resistance: HRN EN 12210:2001 - C3

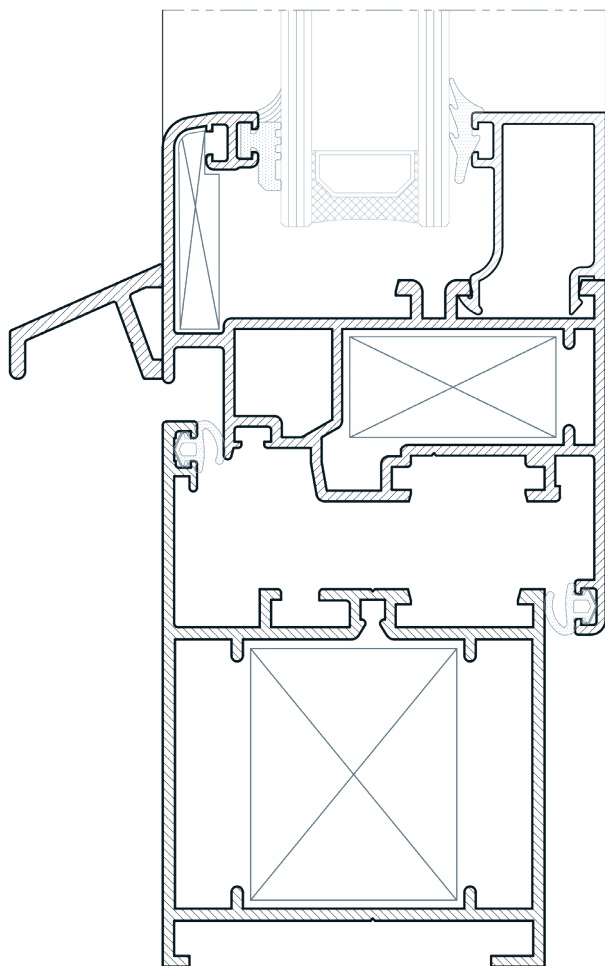

Glazing infill (mm):

6-37

Frame (mm):

50

Sash (mm):

58

Surface treatment options:

Colour powder coating Anodized

Extrusion alloy:

6060 T6

Polyamide strip length (mm):

Gaskets:

EPDM

EPDM+foam

